

- 1
- 2
- 3
- 4
- 5
- 6
- 7
- 8
- 9
- 10
- 11
- 12
- 13
- 14
- 15
- 16
- 17
- 18
- 19

VERSIONS

- Type **A**: with bores for countersunk screws
- Type **B**: with bores for countersunk screws and centering attachments

HINGE LEAFS

- Stainless steel **NI**
Martensite (C1)
- Matte shot-blasted finish **GS**
 - Epoxy resin coating
 - Black, RAL 9005, textured finish **SW**

HINGE PIN

- Stainless steel AISI 440B
- Case hardened
 - With special grease lubricated

SHIM WASHERS

- Stainless steel AISI 301
- With special grease lubricated

INFORMATION

Heavy duty hinges GN 237.3 are designed for use under tough conditions and are distinguished by a compact design. The hinge pins are integral and allow the hinges to be used in environments with strong vibrations and shocks.

The material of the hinge leaves (Version NI) is very robust and, thanks to the martensite structure, is suitable for use in aggressive environments, albeit subject to some restrictions. Wear is minimized by the effective friction pairing of the hinge components and lubrication.

The type B hinge has centering attachments that prevent lateral slippage under high loads and protect the mounting screws from impermissible transverse force.

ACCESSORIES

- GN 2370: Spacer plates.
- GN 2372: Plates.
- GN 2374: Rubber Bumper Stops.

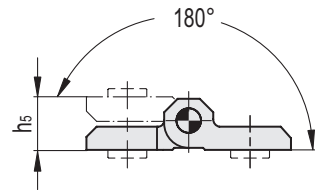

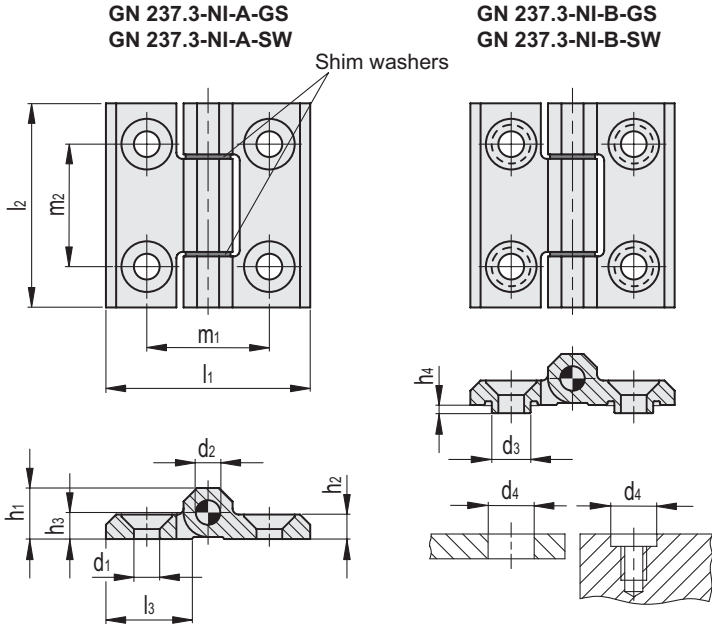

Conversion Table	
1 mm = 0.039 inch	
l1	
mm	inch
50	1.95
60	2.34
80	3.12

GN 237.3-NI-A-GS INOX STAINLESS STEEL METRIC

Code	Description	l1	l2	d1	d2	h1	h2	h3	h5	l3	m1	m2	⚖
GN.74551	GN 237.3-NI-50-50-A-GS	50	50	6.3	6	12.5	6	6.5	13	21	30	30	112
GN.74559	GN 237.3-NI-60-60-A-GS	60	60	8.3	8	16	8	8.5	17	25.5	36	36	210
GN.74583	GN 237.3-NI-80-80-A-GS	80	80	10.3	10	20	10	10.5	21	36	50	50	468

GN 237.3-NI-A-SW

Code	Description	l1	l2	d1	d2	h1	h2	h3	h5	l3	m1	m2	⚖
GN.74553	GN 237.3-NI-50-50-A-SW	50	50	6.3	6	12.5	6	6.5	13	21	30	30	112
GN.74561	GN 237.3-NI-60-60-A-SW	60	60	8.3	8	16	8	8.5	17	25.5	36	36	210
GN.74585	GN 237.3-NI-80-80-A-SW	80	80	10.3	10	20	10	10.5	21	36	50	50	468

GN 237.3-NI-B-GS

Code	Description	l1	l2	d1	d2	d3	d4 +0.5	h1	h2	h3	h4	h5	l3	m1	m2	⚖
GN.74555	GN 237.3-NI-50-50-B-GS	50	50	6.3	6	9.5	10	12.5	6	6.5	2	13	21	30	30	116
GN.74563	GN 237.3-NI-60-60-B-GS	60	60	8.3	8	12.5	13	16	8	8.5	3	17	25.5	36	36	220
GN.74587	GN 237.3-NI-80-80-B-GS	80	80	10.3	10	14.5	15	20	10	10.5	4	21	36	50	50	495

GN 237.3-NI-B-SW

Code	Description	l1	l2	d1	d2	d3	d4 +0.5	h1	h2	h3	h4	h5	l3	m1	m2	⚖
GN.74557	GN 237.3-NI-50-50-B-SW	50	50	6.3	6	9.5	10	12.5	6	6.5	2	13	21	30	30	116
GN.74565	GN 237.3-NI-60-60-B-SW	60	60	8.3	8	12.5	13	16	8	8.5	3	17	25.5	36	36	220
GN.74589	GN 237.3-NI-80-80-B-SW	80	80	10.3	10	14.5	15	20	10	10.5	4	21	36	50	50	495